



US007336797B2

(12) **United States Patent**
Thompson et al.

(10) **Patent No.:** **US 7,336,797 B2**
(45) **Date of Patent:** **Feb. 26, 2008**

(54) **APPARATUS AND METHOD FOR GENERATING ACOUSTIC ENERGY IN A RECEIVER ASSEMBLY**

(75) Inventors: **Stephen C. Thompson**, Naperville, IL (US); **David E. Schafer**, Glen Ellyn, IL (US); **Daniel M. Warren**, Geneva, IL (US)

(73) Assignee: **Knowles Electronics, LLC.**, Itasca, IL (US)

(*) Notice: Subject to any disclaimer, the term of this patent is extended or adjusted under 35 U.S.C. 154(b) by 359 days.

(21) Appl. No.: **10/842,654**

(22) Filed: **May 10, 2004**

(65) **Prior Publication Data**

US 2004/0258260 A1 Dec. 23, 2004

Related U.S. Application Data

(60) Provisional application No. 60/469,154, filed on May 9, 2003.

(51) **Int. Cl.**
H04R 11/02 (2006.01)

(52) **U.S. Cl.** **381/418**; 381/417; 381/324

(58) **Field of Classification Search** 381/417, 381/418, 312-331

See application file for complete search history.

(56) **References Cited**

U.S. PATENT DOCUMENTS

1,630,009 A 5/1927 Hopkins
1,744,032 A 1/1930 Baldwin

1,950,857 A	3/1934	McGall	
2,496,483 A *	2/1950	Massa	381/166
3,515,818 A *	6/1970	Tibbetts	381/189
5,246,353 A *	9/1993	Sohn	417/413.1
6,658,134 B1 *	12/2003	van Hal et al.	381/418
2001/0011615 A1 *	8/2001	Iwasa et al.	181/172
2001/0012375 A1	8/2001	Miller et al.	
2003/0048920 A1	3/2003	Van Halteren et al.	

FOREIGN PATENT DOCUMENTS

JP	7-131893	5/1995
JP	11-308691	11/1999

OTHER PUBLICATIONS

Partial International Search Report for Application No. PCT/US04/014564 dated Dec. 20, 2004.

* cited by examiner

Primary Examiner—Sinh Tran

Assistant Examiner—Joseph Saunders, Jr.

(74) *Attorney, Agent, or Firm*—Marshall, Gerstein & Borun LLP

(57) **ABSTRACT**

A receiver assembly includes a housing having a fixed housing portion and a shiftable housing portion cooperating to define a hollow cavity. A flexible membrane secured between the fixed housing portion and the shiftable housing portion and adapted to allow relative motion between the fixed and shiftable housing portions. The receiver assembly further includes a magnetic motor assembly including a displaceable drive rod; and a link assembly having a first end fixedly attached to an inner surface of the shiftable housing and a second end coupled to the drive rod. The link assembly translates the shiftable housing portion relative to the fixed housing portion in response to the displacement of the drive rod.

25 Claims, 12 Drawing Sheets

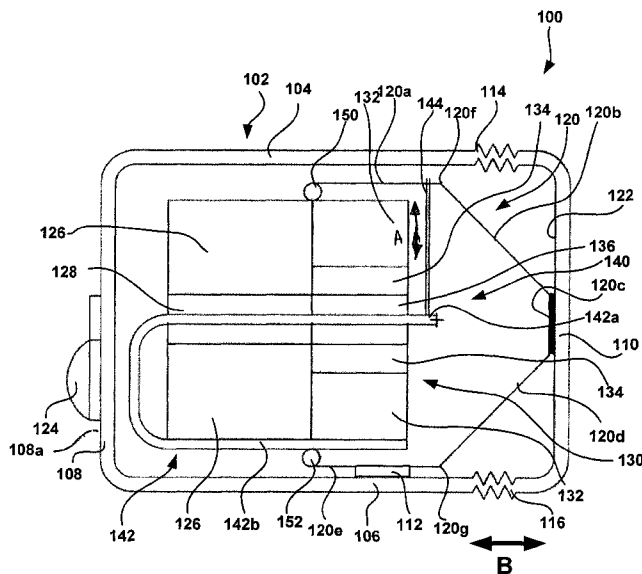

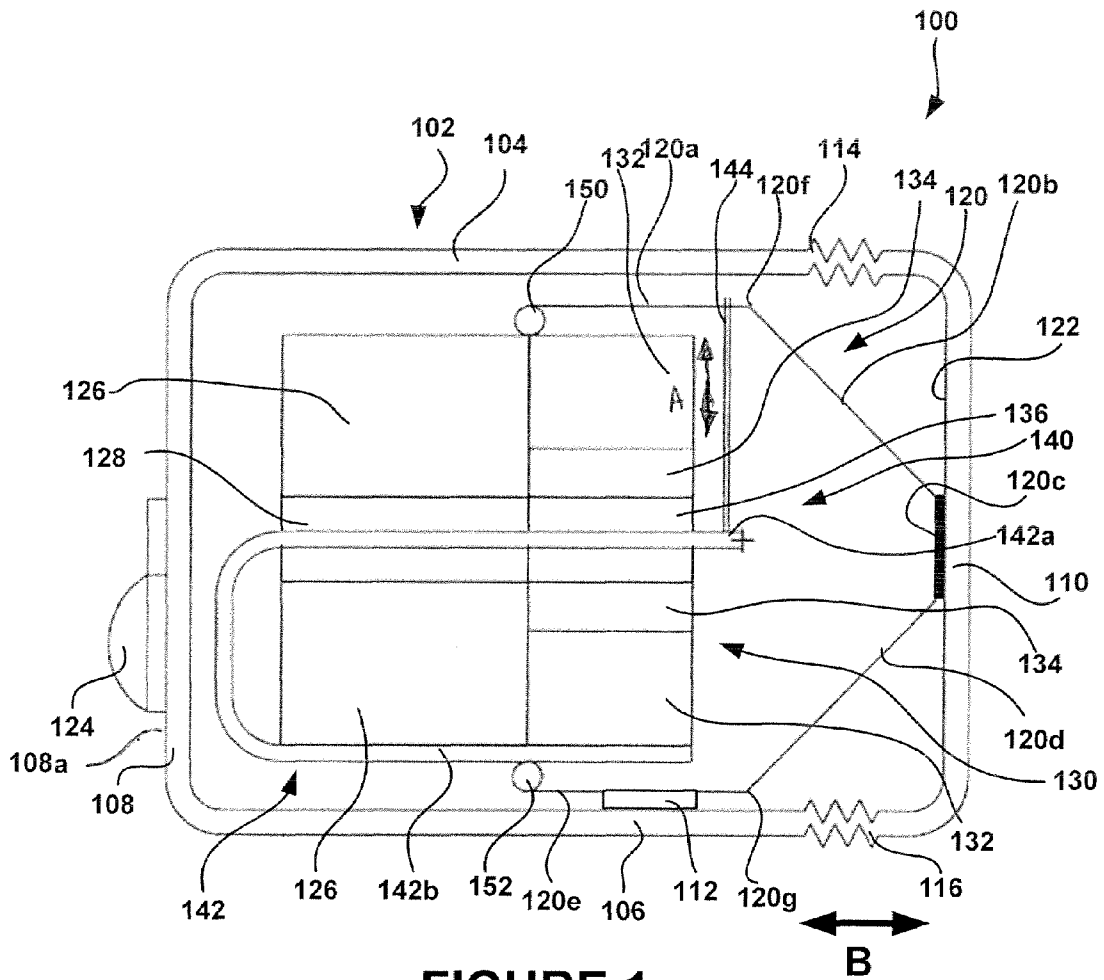

FIGURE 1

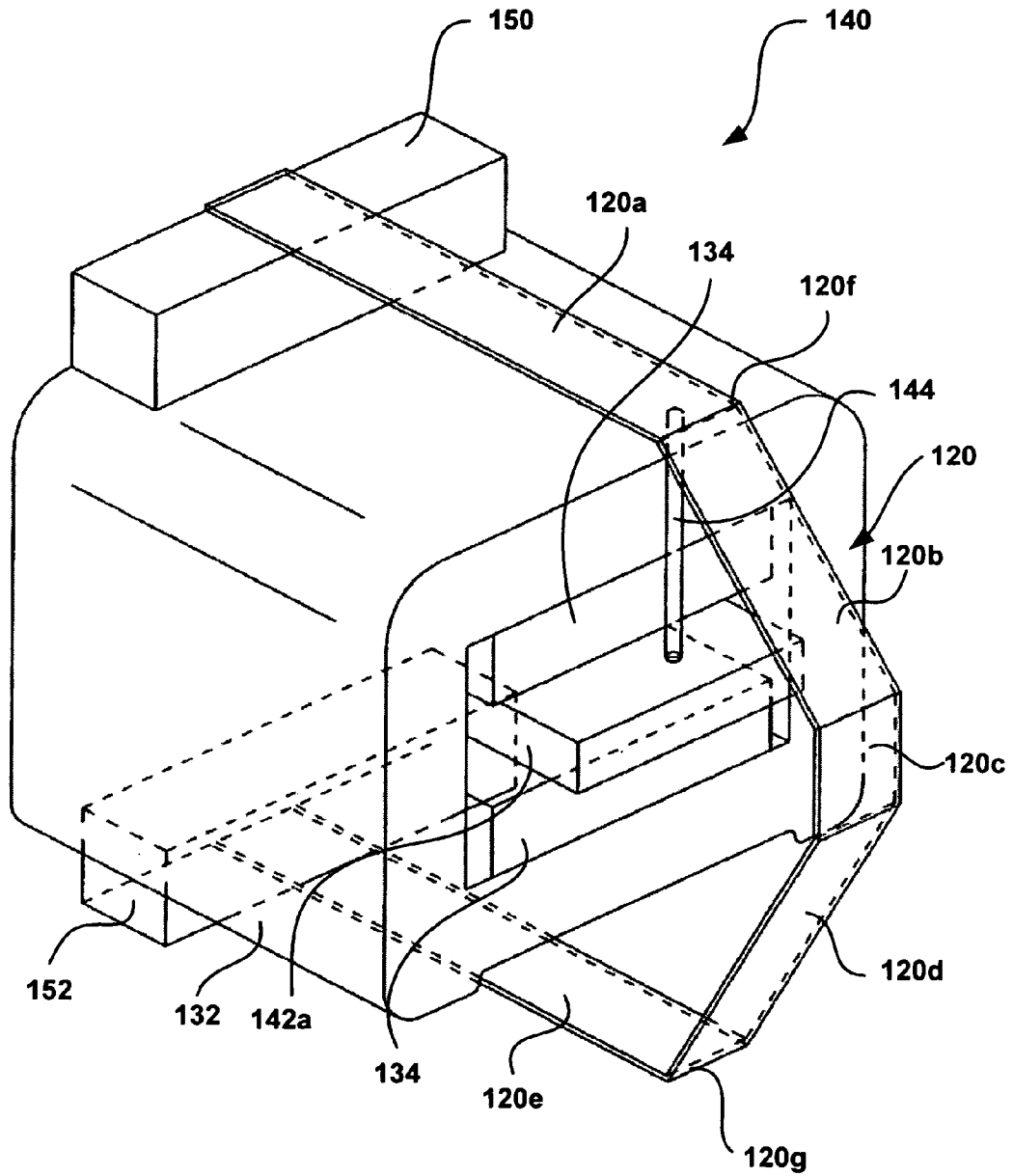

FIGURE 2

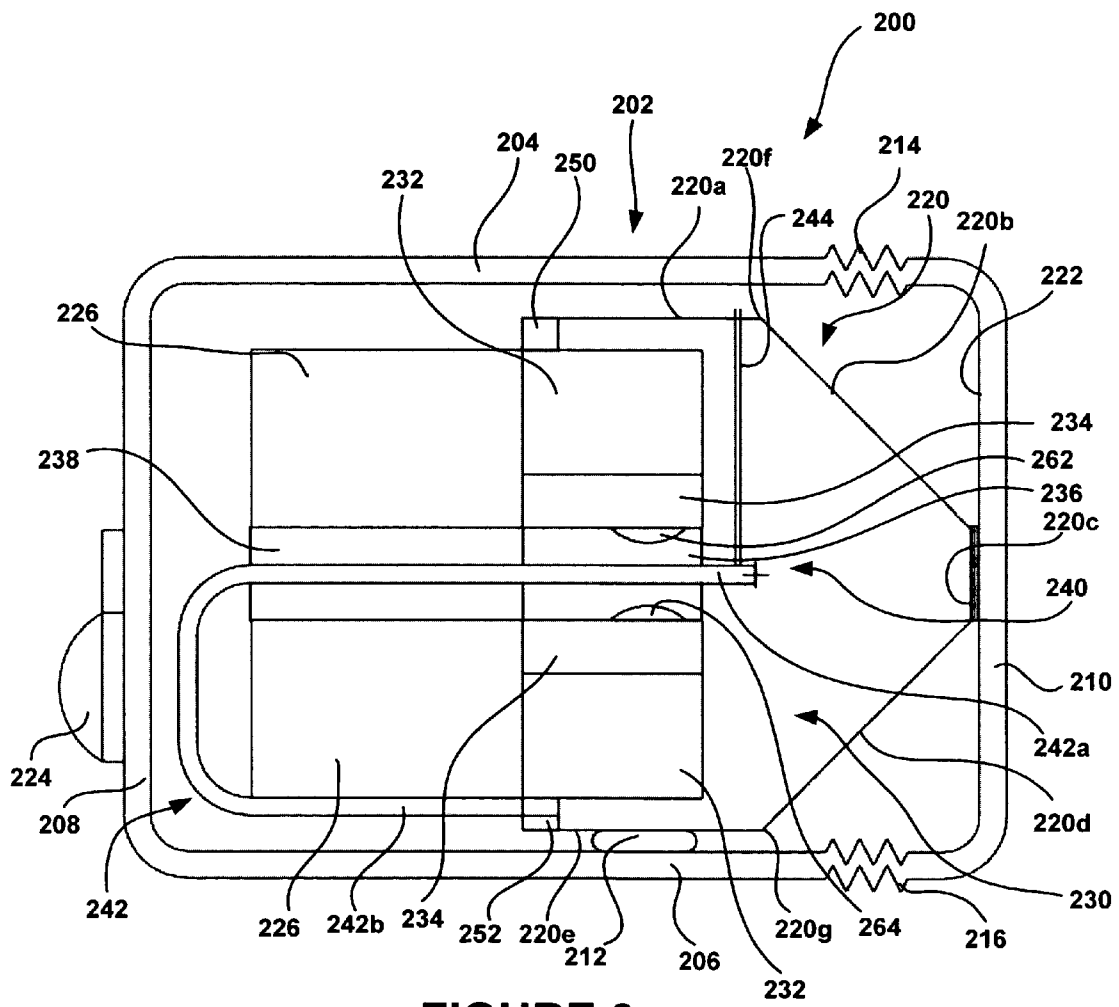

FIGURE 3

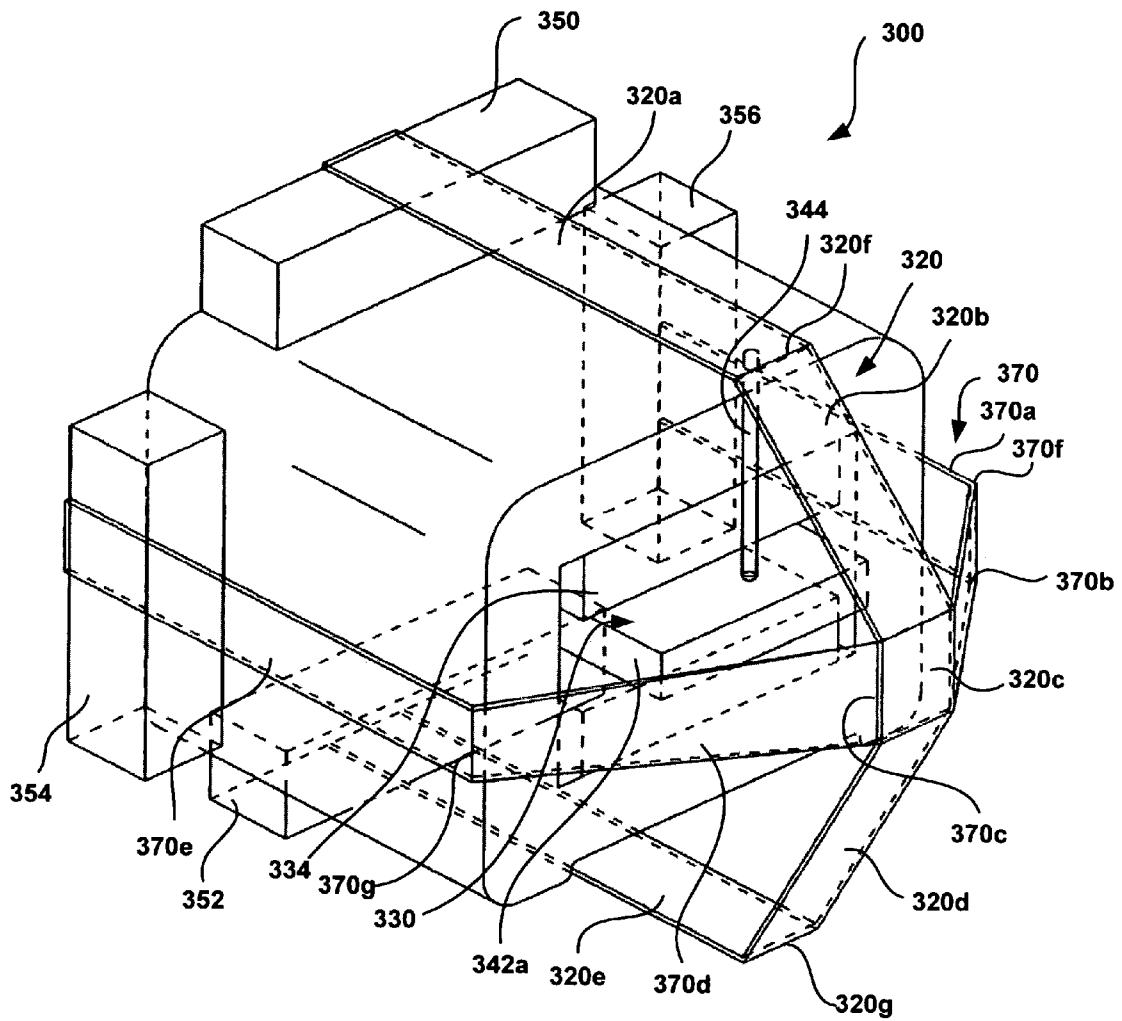

FIGURE 4

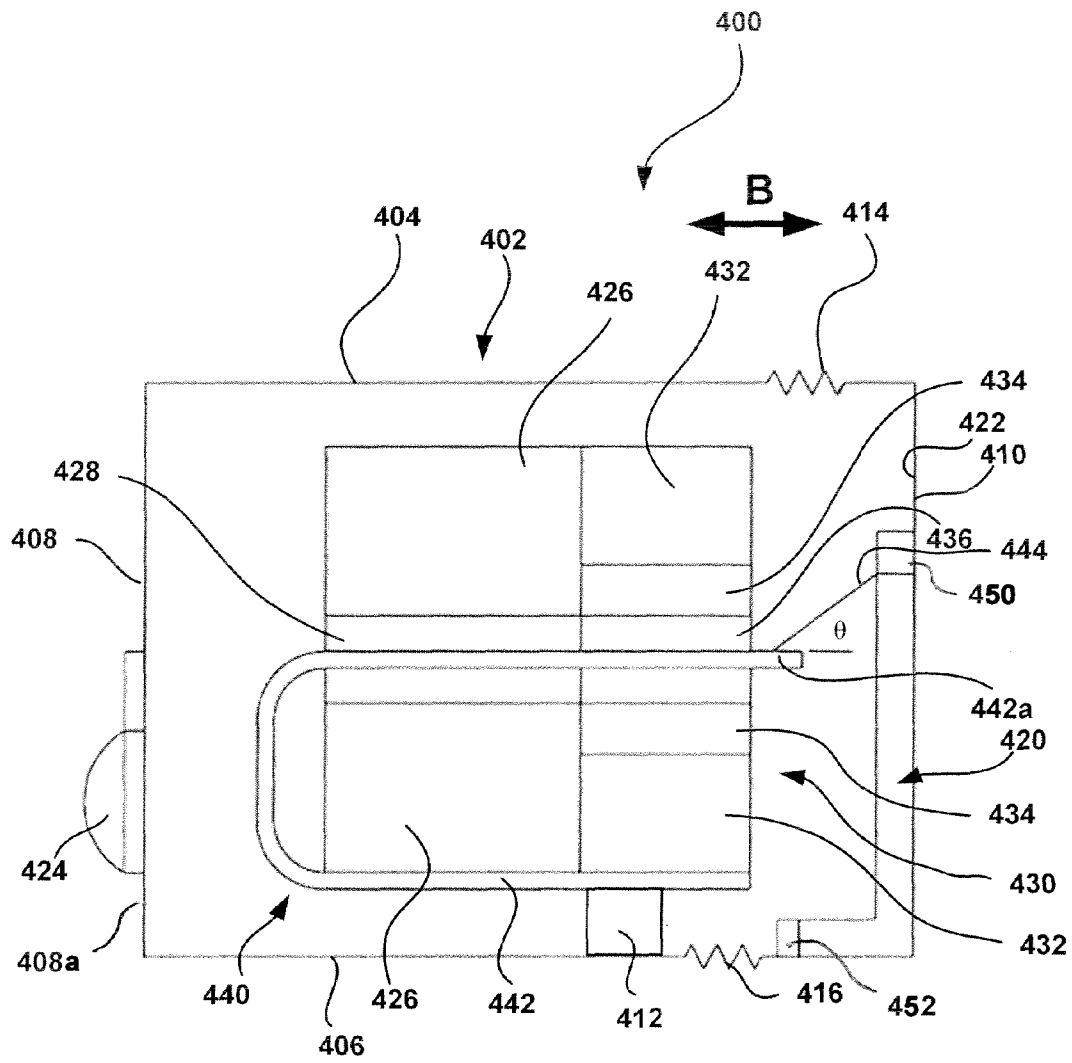

FIGURE 5

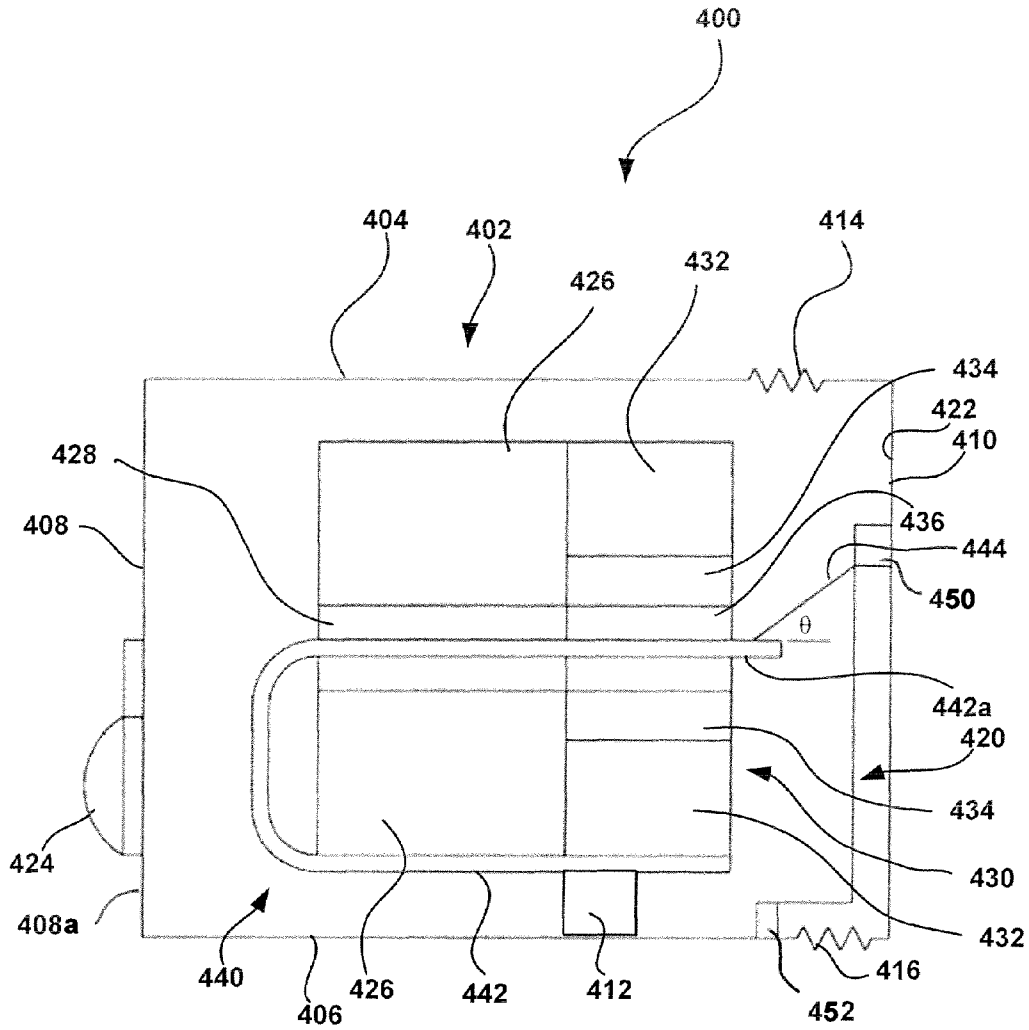

FIGURE 6

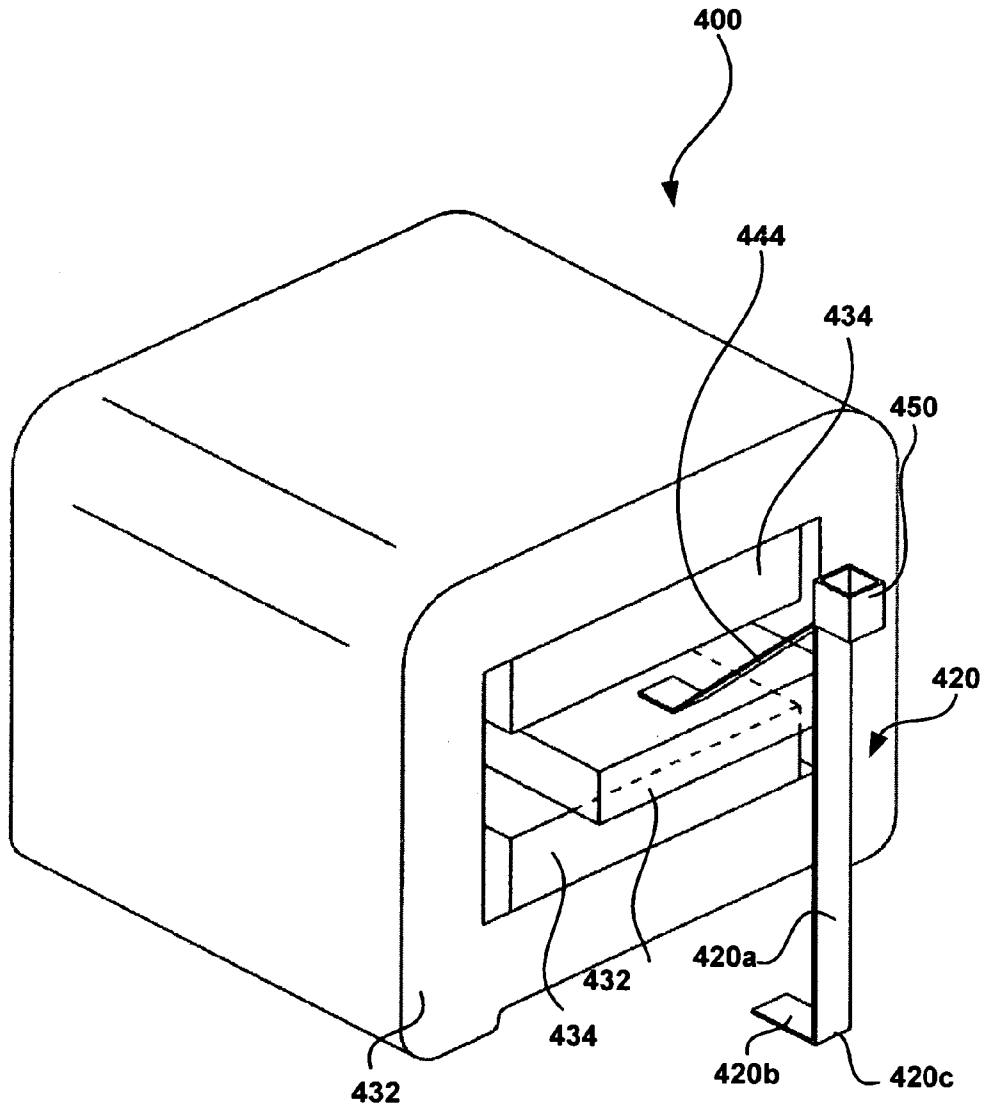

FIGURE 7

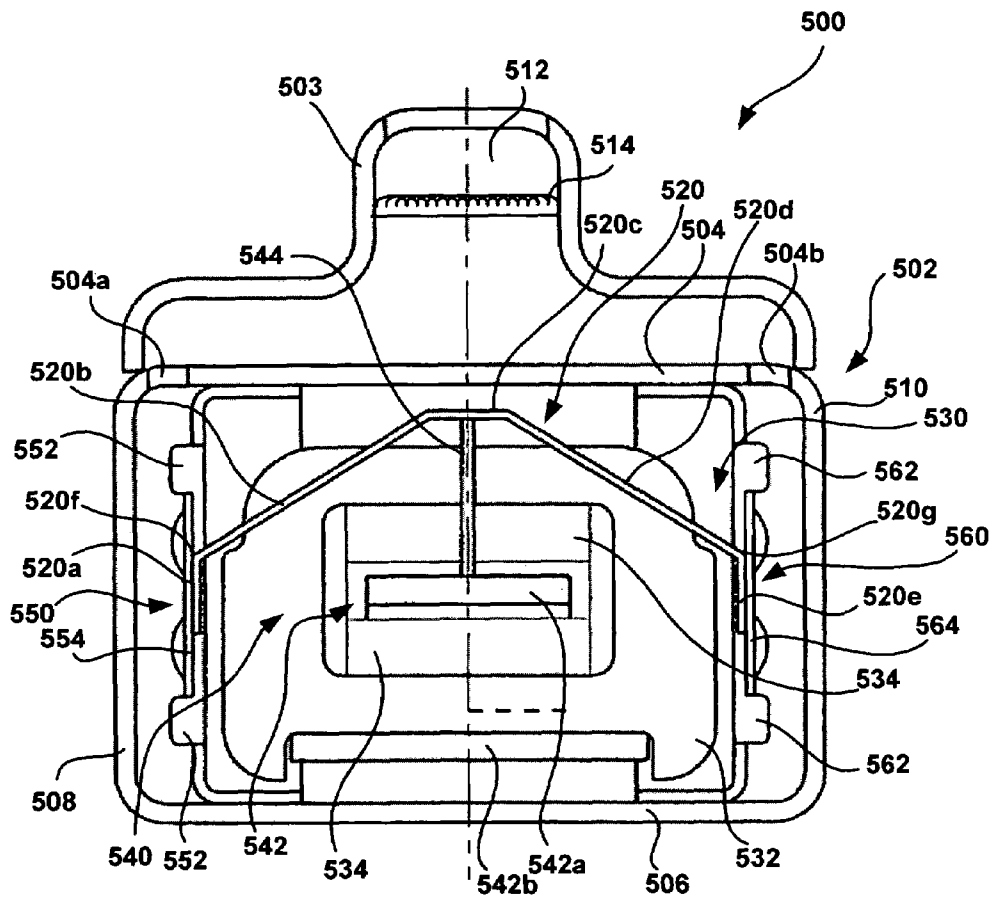

FIGURE 8

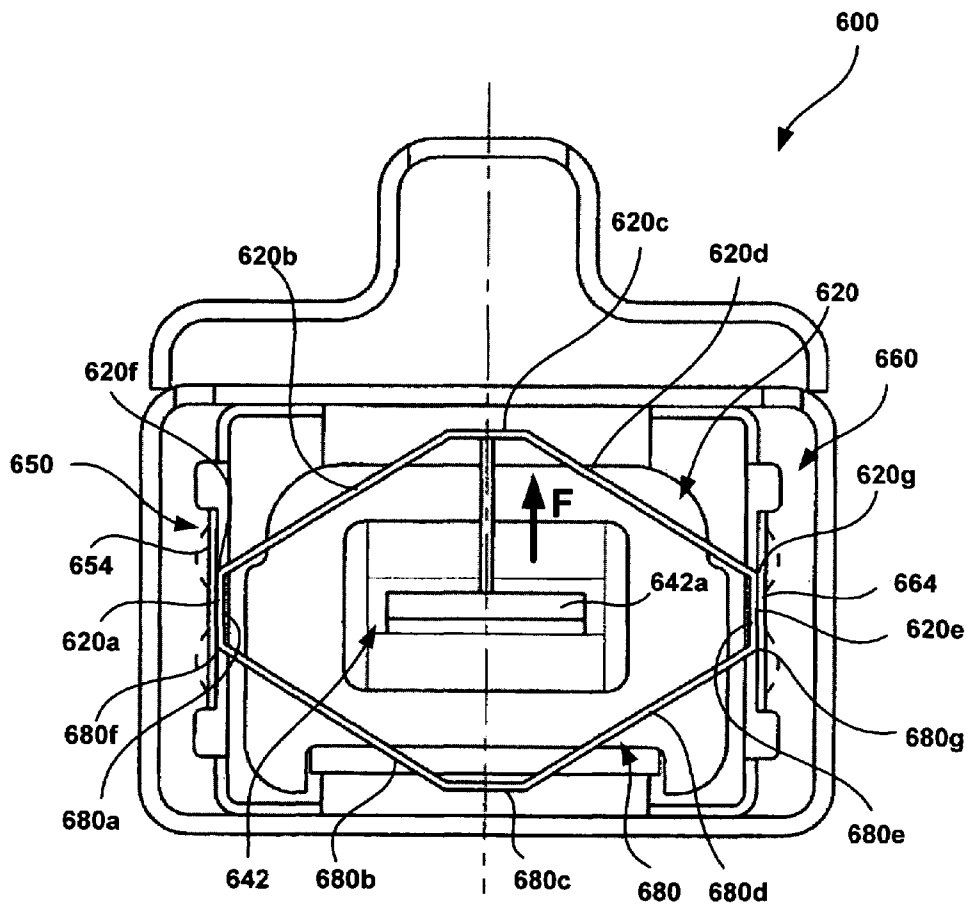

FIGURE 9

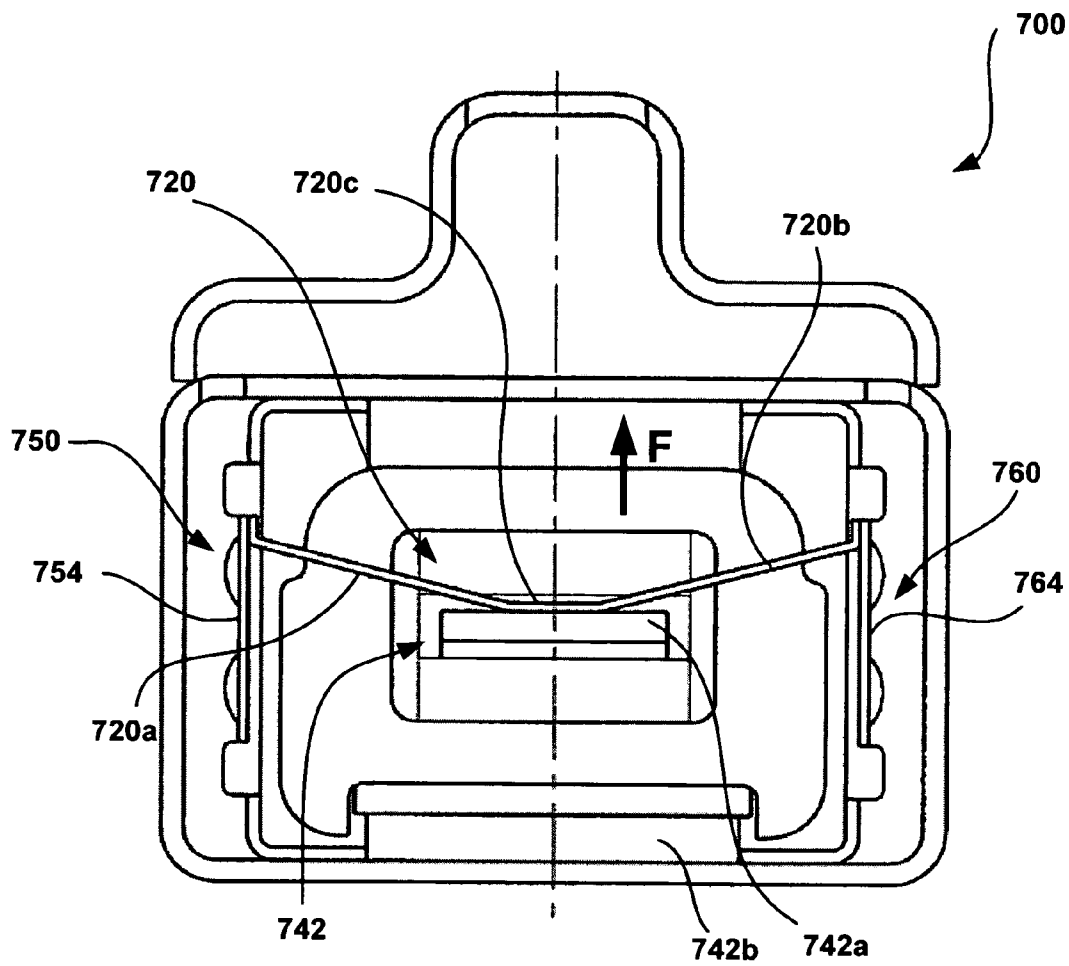

FIGURE 10

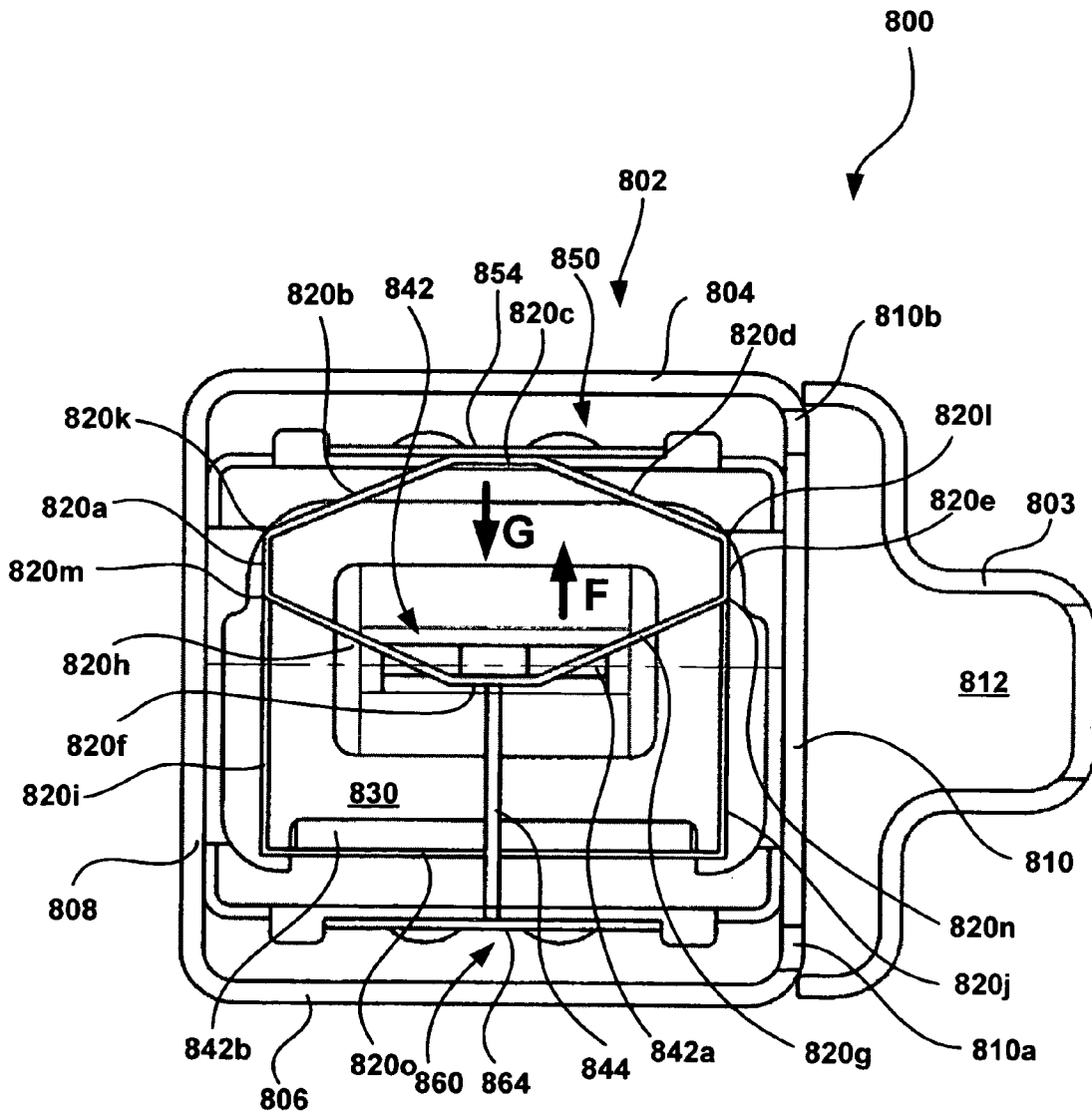

FIGURE 11

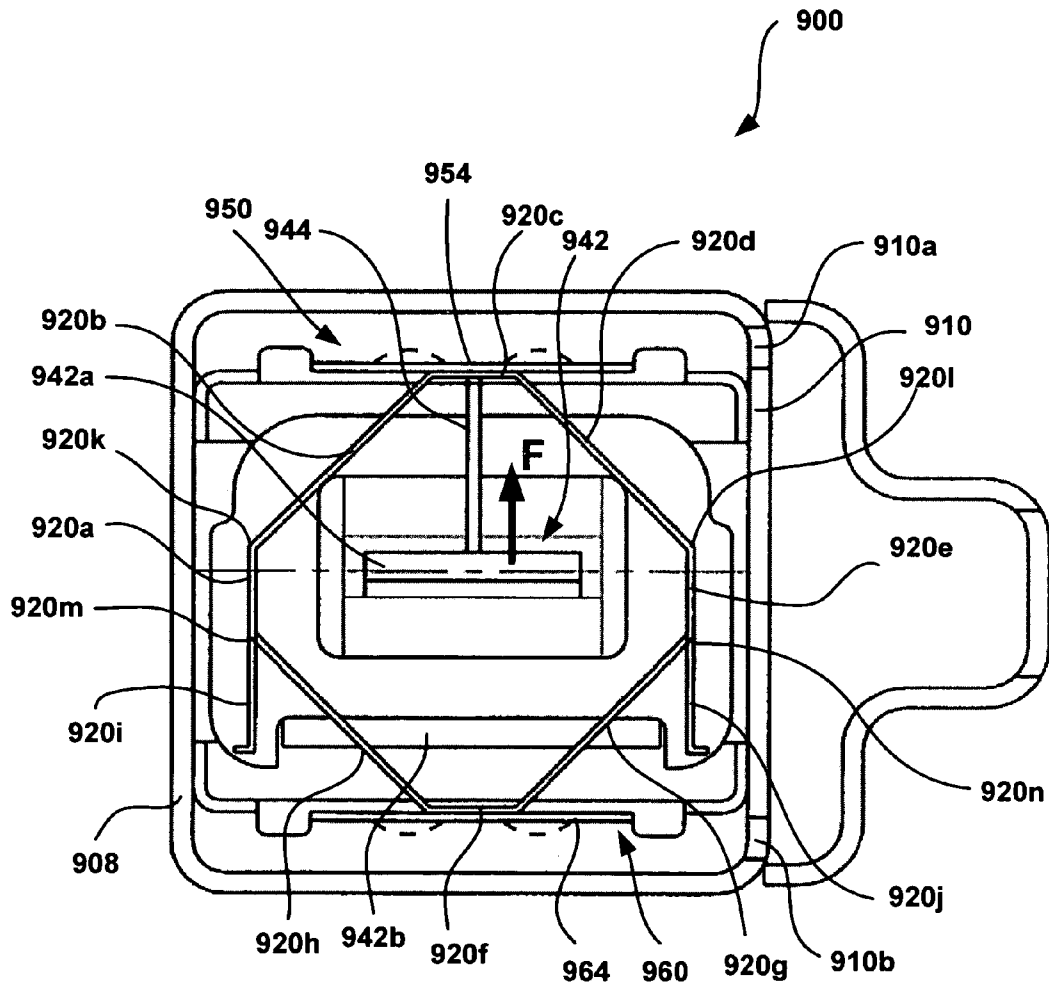

FIGURE 12

**APPARATUS AND METHOD FOR
GENERATING ACOUSTIC ENERGY IN A
RECEIVER ASSEMBLY**

CROSS-REFERENCE TO RELATED PATENT
APPLICATION

This patent claims the benefit of U.S. Provisional Application No. 60/469,154, filed May 9, 2003, the disclosure of which is hereby incorporated herein by reference in its entirety for all purposes.

Further this patent is related to U.S. patent application Ser. No. 10/842,663, filed concurrently (May. 10, 2004), entitled "Apparatus and Method for Generating Acoustic Energy in a Receiver Assembly", the disclosure of which is hereby expressly incorporated herein by reference in its entirety for all purposes.

TECHNICAL FIELD

This patent generally relates to receivers used in listening devices, such as hearing aids or the like, and more particularly, to a diaphragm assembly for use in a vibration-balanced receiver assembly capable of maintaining performance within a predetermined frequency range and a method of manufacturing the same.

BACKGROUND

Hearing aid technology has progressed rapidly in recent years. Technological advancements in this field continue to improve the reception, wearing-comfort, life-span, and power efficiency of hearing aids. With these continual advances in the performance of ear-worn acoustic devices, ever-increasing demands are placed upon improving the inherent performance of the miniature acoustic transducers that are utilized. There are several different hearing aid styles including: Behind-The-Ear (BTE), In-The-Ear or All In-The-Ear (ITE), In-The-Canal (ITC), and Completely-In-The-Canal (CTC).

Generally, a listening device, such as a hearing aid, includes a microphone assembly, an amplifier and a receiver (speaker) assembly. The microphone assembly receives vibration energy, i.e. acoustic sound waves in audible frequencies, and generates an electronic signal representative of these sound waves. The amplifier accepts the electronic signal, modifies the electronic signal, and communicates the modified electronic signal (e.g., processed signal) to the receiver assembly. The receiver assembly, in turn, converts the increased electronic signal into vibration energy for transmission to a user.

Conventionally, the receiver assembly utilizes moving parts (e.g., armature, diaphragm, etc.) to generate acoustic energy in the ear canal of the hearing aid wearer. If the receiver assembly is in contact with another hearing aid component, the momentum of these moving parts will be transferred from the receiver assembly to the component and from the component back to the microphone assembly. This transferred momentum or energy may then cause unintended electrical output from the microphone, i.e., feedback. This mechanism of unwanted feedback limits the amount of amplification that can be applied to the electric signal representing the received sound waves. In many situations, this limitation is detrimental to the performance of the hearing aid. Consequently, it is desirable to reduce the vibration and/or magnetic feedback that occurs in the receiver assembly of the hearing aid or other similar devices.

BRIEF DESCRIPTION OF THE DRAWINGS

For a more complete understanding of the disclosure, reference should be made to the following detailed description and accompanying drawings wherein:

FIG. 1 is a cross-sectional view of an exemplary embodiment of a receiver assembly;

FIG. 2 is a perspective view of an exemplary motor assembly shown FIG. 1;

FIG. 3 is a cross-sectional view of another embodiment of a receiver assembly;

FIG. 4 is a perspective view of another embodiment of a motor assembly;

FIG. 5 is a cross-sectional view of an alternate embodiment of a receiver assembly;

FIG. 6 is a cross-sectional view of another alternate embodiment of a receiver assembly;

FIG. 7 is a perspective view of a motor assembly of shown FIGS. 5 and 6;

FIG. 8 is a front view of a described embodiment of a receiver assembly;

FIG. 9 is a front view of another described embodiment of a receiver assembly;

FIG. 10 is a front view of another described embodiment of a receiver assembly;

FIG. 11 is a front view of another described embodiment of a receiver assembly; and

FIG. 12 is a front view of another described embodiment of a receiver assembly.

DETAILED DESCRIPTION

While the present disclosure is susceptible to various modifications and alternative forms, certain embodiments are shown by way of example in the drawings and these embodiments will be described in detail herein. It will be understood, however, that this disclosure is not intended to limit the invention to the particular forms described, but to the contrary, the invention is intended to cover all modifications, alternatives, and equivalents falling within the spirit and scope of the invention defined by the appended claims.

It should also be understood that, unless a term is expressly defined in this patent using the sentence "As used herein, the term '_____' is hereby defined to mean . . ." or a similar sentence, there is no intent to limit the meaning of that term, either expressly or by implication, beyond its plain or ordinary meaning, and such term should not be interpreted to be limited in scope based on any statement made in any section of this patent (other than the language of the claims). To the extent that any term recited in the claims at the end of this patent is referred to in this patent in a manner consistent with a single meaning, that is done for sake of clarity only so as to not confuse the reader, and it is not intended that such claim term be limited, by implication or otherwise, to that single meaning. Unless a claim element is defined by reciting the word "means" and a function without the recital of any structure, it is not intended that the scope of any claim element be interpreted based on the application of 35 U.S.C. §112, sixth paragraph.

The following patent applications describe techniques that may be employed in certain embodiments of receiver assemblies: U.S. patent application Ser. No. 10/719,809, entitled "Apparatus For Creating Acoustic Energy In A Balanced Receiver Assembly And Manufacturing Method Thereof," filed on Nov. 21, 2003; U.S. patent application Ser. No. 10/719,765, entitled "Apparatus For Energy Transfer In A Balanced Receiver Assembly And Manufacturing

Method Thereof,” filed on Nov. 21, 2003; both applications claim the benefit of U.S. Provisional Patent Application No. 60/428,604, filed on Nov. 22, 2002; U.S. patent application Ser. No. 09/755,664, entitled “Vibration Balanced Receiver,” filed on Jan. 5, 2001, is a continuation-in-part of the now-abandoned U.S. patent application Ser. No. 09/479,134, entitled “Vibration Balanced Receiver,” filed Jan. 7, 2000, U.S. patent application Ser. No. 09/809,130, entitled “Vibration-Dampening Receiver Assembly”, filed on Mar. 15, 2003. These patent applications are hereby incorporated by reference herein in their entireties for all purposes. It is to be understood, however, that the techniques described in these patent applications are not required.

FIGS. 1 and 2 illustrate an exemplary embodiment of a receiver assembly 100. The receiver assembly 100 includes a housing 102 that may be, for example, rectangular in cross-section with a planar top 104, a bottom 106, and side walls 108, 110. In alternate embodiments, the housing 102 can be manufactured in a variety of configurations, such as, a cylindrical shape, a D-shape, a trapezoid shape, a roughly square shape, or any other desired geometry. In addition, the scale and size of the housing 102 may vary based on the intended application, operating conditions, required components, etc. Moreover, the housing 102 can be manufactured from a variety of materials, such as, for example, stainless steel, alternating layers of conductive materials, or alternating layers of non-conductive materials (e.g., metal particle-coated plastics). The bottom 106 of the housing 102 may include a plurality of supporting members 112 adapted to support both a magnet assembly 130 and a motor assembly 140. It will be understood that a variety of supporting structures such as, for example, a u-shape plate, a pair of deformed corners, or a glue fillet, may be utilized to support the magnet assembly and motor assemblies 130, 140.

A first and second bellows-like member 114, 116 are provided in the surface of the housing 102 and allow motion in response to the flexing of a linkage assembly 120. The first and second bellows-like member 114, 116 may have an accordion like structure including a plurality of ridges and valleys, may be a pliant sheet of material, and may be any other type of flexible membrane capable of expanding and contracting in response to the flexure of the linkage assembly 120. For example, as is shown in the embodiment depicted in FIG. 1, the first bellows-like member 114 may be disposed in the top 104 of the housing 102, and the second bellows-like member 116 may be disposed in the bottom 106 of the housing 102. Separate housing sections incorporating the bellows-like members 114 and 116 may be provided, or the bellows-like members 114 and 116 may otherwise be provided within the housing 102. In other words, the bellows-like members 114, 116 may be incorporated separately into the top 104 and the bottom 106, respectively, or can be a single flexible membrane disposed and joining a fixed portion of the housing 102 to a moveable portion of the housing 102. In operation, the first and second bellows-like member 114, 116 allow movement of a radiating face or piston diaphragm 122 in response to the movement of the linkage assembly 120 to thereby pump or force air.

The radiating face or piston diaphragm 122 attaches to the inner surface of the side wall 110 by bonding or any other suitable method of attachment. The radiating face 122 translates relative to the housing 102 in accordance with the movement of the linkage assembly 120 driving the first and second bellows-like members 114, 116. The radiating face 122 may be manufactured from mylar or other suitable material of suitable stiffness and rigidity to provide an output acoustical signal of the receiver assembly 100 that corre-

sponds to the input audio signal received at an electrical terminal 124 positioned on an external surface 108a of the side wall 108.

The receiver assembly 100 further includes a drive coil 126 having a central channel defining a first air gap 128 therethrough. The illustrated drive coil 126 is sized to conform to the shape of the housing 102, but may produced in a variety of shapes and sizes that may or may not correspond to the housing shape. For example, in one embodiment the drive coil 126 may be manufactured having an overall rectangular shape to correspond to the rectangular shape of the housing 102. The drive coil 126 is made of electrically conductive materials having a thickness and a plurality of turns such as the drive coil disclosed in U.S. patent application Ser. No. 09/928,673, entitled “Low Capacitance Receiver Coil,” filed on Aug. 21, 2001, the disclosure of which is hereby incorporated herein by reference in its entirety for all purposes. In alternate embodiments, the drive coil 126 may be made of alternating layers of insulating materials (e.g. copper-polymer based film).

The receiver assembly 100 further includes a magnet assembly 130 including a pair of drive magnets 134 fixedly attached to a magnetic yoke 132. The magnet assembly 130 may generally be shaped to correspond to the shape and configuration of the housing 102, but may be in various shapes and sizes. The magnetic yoke 132 forms a rectangular frame having a central tunnel or channel defining an enclosure into which the drive magnets 134 mount and form a second air gap 136.

The magnetic yoke 132 may be manufactured of soft magnetic materials having a high permeability and a high saturation induction such as, for example, nickel-iron alloy, iron-silicon alloy, or cobalt-iron vanadium alloy, having a thickness to carry the electromagnetic flux of the drive magnets 134 and the drive coil 126. The drive magnets 134 may be manufactured from a variety of materials, such as, for example, a permanent magnet material (e.g., aluminum-nickel-cobalt, ferrite), a rare earth magnet material such as, for example samarium-cobalt (SmCo), neodymium-iron-boron (NdFeB), having a thickness to provide sufficient electromagnetic flux density within the second air gap 136.

The receiver assembly 100 further includes a motor assembly 140 including an armature 142, a link or drive rod 144, and at least one member of the linkage assembly 120. The linkage assembly 120 is shown generally semi-lateral, having a plurality of linear link members 120a, 120b, 120c, 120d, 120e and vertices 120f, 120g. The linkage assembly 120 may be formed into a variety of shapes and configurations based on the intended application, operating conditions, required components, etc. The linkage assembly 120 may be fabricated from a flat stock material such as a thin strip of metal or foil having a surface that defines a plane, and a width that is perpendicular to the plane. Alternately, the linkage assembly 120 may be formed of plastic or some other pliant material. Each of the link members 120a, 120b, 120c, 120d, 120e is illustrated as a substantially flat or linear component connected together at the vertices 120f, 120g. The transitions from one link member (e.g. 120e to 120d, and 120a to 120b) to another link member may be abrupt and sharply angled such as shown at the exemplary vertices 120f, 120g, or may be curved, or even expanded to include at least one short span, such as a link vertex 120c.

The armature 142 may be configured as a generally U-shaped strap having first and second opposing legs 142a, 142b, respectively. One skilled in the art will appreciate the principles and advantages of the embodiments described herein may be useful with all types of receivers, such as, for

5

example, receivers employing an E-shaped armature. The armature **142** extends through the first air gap **128** of the drive coil **126** and the second air gap **136** of the magnet assembly **130**. The drive rod **144**, attached to the armature **142** adjacent to the free end of the first leg **142a**, is positioned within the housing **102**. The drive rod **144**, in turn, couples to the inner surface of the link member **120a**, for example by adhesive bonding, and hence to the remainder of the drive linkage assembly **120**. In alternate embodiments, the link member **120a** may include an aperture to allow the drive rod **144** to extend therethrough and slideably couples the link member **120a** to the linkage assembly **120**. The magnet assembly **130** surrounds the first leg **142a** of the armature **142** and provides a permanent magnetic field within the second air gap **136**.

At least one mounting member or spacer, two are illustrated as mounting members **150**, **152** are introduced to support and secure the linkage assembly **120**. The mounting members **150**, **152** may be adhesive bumps, may be formed portions of the housing **102**, and may be sized to space the linkage assembly **120** away from the magnet assembly **130** and the housing **102**. The thickness and material of the mounting members **150**, **152** may vary depending on the requirements of the application. It will be understood that a variety of mounting members such as, for example, a glue fillet, may be utilized to support the linkage assembly. In alternate embodiment, a spacer (not depicted) having a hollow section may be placed between the linkage assembly **120** and the magnet assembly **130** to support the linkage assembly **120**.

The outer surface of the mounting member **150** secures to the inner surface of the member **120a** by bonding or any other suitable method of attachment, and the inner surface of the mounting member **150** secures to the outer surface of the magnet assembly **130** by bonding or any other suitable method of attachment. Similarly, the inner surface of the mounting member **152** secures to the outer surface of the second leg **142b** of the armature **142** by bonding or any other suitable method of attachment, and the outer surface of the mounting member **152** secures to the inner surface of the member **120e** by bonding or any other suitable method of attachment.

In operation, excitation of the drive coil **126** (as shown in FIG. 1) magnetizes the armature **142**. Interaction of the first leg **142a** with the magnetic field causes the first leg **142a** of the armature **142** to vibrate, which leads to the movement of the drive rod **144**. When the drive rod **144** moves a first direction (e.g. up and down, as shown by the arrow), the link members **120a**, **120b**, **120c**, **120d**, **120e**, **120f**, and **120g** of the linkage assembly **120** move in response to the drive rod **144**. The motion of the drive rod **144** is converted into at vertex **120c** of the linkage assembly **120**, resulting in motion in a second direction (e.g., movement in the direction shown by the arrow B) of the radiating face **122** of the housing **102**. As an example, upward movement by the first leg **142a** generates a movement of the drive rod **144** substantially aligned with the first direction, which in turn, generates a movement of vertex **120c** substantially aligned with the second direction, resulting in movement of the radiating face **122** of the housing **102**.

The bellow-like members **114**, **116** of the housing **102** as shown in FIG. 1 enclosed the drive coil **126**, the magnet assembly **130**, and the motor assembly **140** from the outside, but allow the radiating face **122** to move freely in the second direction (as shown by the arrow B). Formed in this manner, the receiver assembly **100** has the advantage of radiating an increased amount of output acoustical signal without a

6

conventional diaphragm and a sound port. In addition, the sound port may be eliminated, thus allowing the receiver assembly **100** to be less susceptible to the accumulation of cerumen and moisture. A device built in accordance with the embodiment illustrated in FIGS. 1 and 2, has the advantage of reduced overall size while providing improved performance characteristics such as sensitivity, noise, stability, compactness, robustness, maintaining high degree of reproducibility and other external and environmental conditions (including shock and debris).

Referring now to FIG. 3, a receiver assembly **200** in accordance with another embodiment of the invention is illustrated. The assembly **200** is similar in construction and function as the assembly **100** illustrated in FIG. 1, and like elements are referred to using like reference numerals wherein, for example **200** and **226** correspond to **100** and **126**, respectively. A first and second formation **262**, **264** are positioned on opposing sides of the inner surface of the magnet assembly **230** to prevent the first leg **242a** of the armature **242** from striking or directly contacting the drive magnet **234**, which in turn, stabilizes the radiating face **222** of the housing **202**. The formations **262**, **264** may be constructed of adhesive or other settable material to provide shock resistance for the receiver assembly **200** by inhibiting large deflections of the first armature leg **242a**. The formations or bumpers **262**, **264** may protect the first armature leg **242a** as disclosed in U.S. application Ser. No. 10/089,861, entitled "Electro-Acoustic Transducer With Resistance to Shock-Waves" filed on Aug. 8, 2000, the disclosure of which is hereby incorporated herein by reference in its entirety for all purposes.

However, the formations **262**, **264** may take the form of various shapes, and have a number of different sizes in different embodiments. Moreover, the formations **262**, **264** can be manufactured from a variety of materials, such as, for example, damping fluid, an elastomer, an epoxy, or a plastic. The damping fluid may be a shock resistant fluid contained within the gap **236** such as disclosed in U.S. Pat. No. 6,041,131, entitled "Shock Resistant Electroacoustic Transducer," issued on Mar. 21, 2000, the disclosure of which is hereby incorporated herein by reference in its entirety for all purposes. In operation, the formations **262**, **264** improve resistance of the receiver assembly **200** during insertion, removal, and cleaning of the cerumen accumulation on the outside of the housing **202**. In alternate embodiments, the formations may be manufactured on the inner surface of the drive coil **226**, on the first armature **242a** within the first air gap **228**, on the first armature **242a** within the second air gap **236**, or on both.

Referring now to FIG. 4, a receiver assembly **300** in accordance with a yet another embodiment of the invention is illustrated. The assembly **300** is similar in construction and function as the assembly **100** illustrated in FIG. 1, and like elements are referred to using like reference numerals wherein, for example **300** and **326** correspond to **100** and **126**, respectively. A second linkage assembly **370** is introduced to restrain inward motion of the radiating face **354**, i.e. motion associated with the second direction (see arrow B of FIG. 1). The second linkage assembly **370** is shown generally semi-lateral, having a plurality of link members **370a**, **370b**, **370c**, **37d**, **370e** and vertices **370f**, **370g**. The second linkage assembly **370** may take the form of various shapes and configurations based on the intended application, operating conditions, required components, etc. The linkage assembly **370** may be fabricated from a flat stock material such as a thin strip of metal or foil having a surface that defines a plane, and a width that is perpendicular to the

plane. Alternately, the linkage assembly **370** may be formed of plastic or some other material. The link members **370a**, **370b**, **370c**, **370d**, **370e** are shown substantially straight and connected together at the vertices **370f**, **370g**. The transitions from one member to its neighbor may be abrupt and sharply angled such as illustrated by the vertices **370f**, **370g**, may be rounded, or may be rounded expanded and include at least one short span, such as the vertex **370c**.

The outer surface of the vertex **370c** fixedly or removably attaches to the inner surface of the vertex **320c** for example by adhesive bonding or other suitable attachment means. The inner surface of the vertex **370c** is symmetrically located on the opposing side of the magnet assembly **330**. In operation, excitation of the drive coil (not depicted) magnetizes the first armature leg **342a**. Interaction of the first armature leg **342a** with the magnetic field causes the first armature leg **342a** to vibrate in the first direction (see arrow A of FIG. 1), which leads to movement of the drive rod **344**. When the drive rod **344** moves in the first direction, the members of the first linkage assembly **320** move in response to the drive **344**. The motion of the drive rod **344** is converted into the second direction at the vertex **320c** of the first linkage assembly **320**. The members of the second linkage assembly **370** prevent the link members **320a**, **320b**, **320c**, **320d**, and **320e** of the first linkage assembly **320** from swinging back and forth in an uncontrolled manner. The motion at vertex **320c** of the first linkage assembly **320** is transferred to the second linkage assembly **370** at the vertex **370c** thereby resulting in motion of the radiating face (e.g., the radiating face **122** shown in FIG. 1) of the receiver assembly **300**. Formed in this manner, the second linkage assembly **370** provides additional support and rigidity to the first linkage assembly **320** of the receiver assembly.

Referring now to FIGS. 5-7, a receiver assembly **400** in accordance with a described embodiment of the invention is illustrated. The assembly **400** is similar in construction and function as the assembly **100** illustrated in FIG. 1, and like elements are referred to using like reference numerals wherein, for example **400** and **426** correspond to **200** and **226**, respectively. A first and second bellows-like member **414**, **416** are provided in the surface of the housing **402** to allow or restrain motion in response to the motion of a linkage assembly **420**. The first bellows-like member **414** may be formed integral to the planar top **404** of the housing **402**, and the second bellows-like member **416** may be formed integral to the bottom **406** of the housing **402** and outside the linkage assembly **420**. In operation, the first and second bellows-like member **414**, **416** allow movement of a radiating face or piston diaphragm **422** in response to the movement of the linkage assembly **420** to thereby pump or force air.

The radiating face or piston diaphragm **422** attaches to the inner surface of the side wall **410** by bonding or any other suitable method of attachment. The radiating face **422** may be manufactured of mylar or other material of suitable stiffness and rigidity to provide output acoustical signals that corresponds to the input audio signal received at the electrical terminal **424** positioned on an external surface **408a** of the side wall **408**.

The receiver assembly **400** further includes a drive coil **426** having a central tunnel or channel defining a first air gap **428** therethrough. The drive coil **426** is sized to conform to the shape of the housing **402**, but may be produced in a variety shapes and sizes that may or may not correspond to the housing shape. For example, in one embodiment the drive coil **426** may be manufactured having an overall rectangular shape corresponding to the rectangular shape of

the housing **402**. The drive coil **426** is made of electrically conductive materials having a thickness and a plurality of space turns such as the drive coil disclosed in U.S. patent application Ser. No. 09/928,673, entitled "Low Capacitance Receiver Coil," filed on Aug. 21, 2001, the disclosure of which is hereby incorporated herein by reference in its entirety for all purposes. In alternate embodiments, the drive coil **426** may be made of alternating layers of insulating materials (e.g., copper-polymer based film).

The receiver assembly **400** further includes a magnet assembly **430** including a drive magnet **434** fixedly attached to a magnetic yoke **432**. The magnet assembly **430** may generally be shaped to correspond to the shape and configuration of the housing **402**, but may be formed to compliment the various shapes and sizes of the different embodiments. The magnetic yoke **432** in the form of a rectangular frame having a relatively large central tunnel or channel forming an enclosure in which the drive magnet **434** are mounted in space relation to form a second air gap **434**.

The magnetic yoke **432** is typically manufactured of magnetically conductive materials having a high permeability and a high saturation induction such as, for example, nickel-iron alloy, iron-silicon alloy, or cobalt-iron vanadium alloy, having a thickness to carry the electromagnetic flux of the drive magnet **434** and the drive coil **426**. The drive magnet **434** is typically manufactured of a rare earth magnet material such as, for example samarium-cobalt (SmCo), neodymium-iron-boron (NdFeB), having a thickness to provide sufficient electromagnetic flux density within the second air gap **436**.

The receiver assembly **400** further includes a motor assembly **440**. The motor assembly **440** includes an armature **442**, a link or drive rod **444**, and at least one linkage assembly **420**. The linkage assembly **420** is shown generally L-shape, having a plurality of link members **420a**, **420b** and vertex **420c**. The linkage assembly **420** may take the form of various shapes and configurations based on the intended application, operating conditions, required components, etc. The linkage assembly **420** may be fabricated from a flat stock material such as a thin strip of metal or foil having a surface that defines a plane, and a width that is perpendicular to the plane. Alternately, the linkage assembly **420** may be formed of plastic or some other material. Each of the link members **420a**, **420b** are shown substantially straight and connected together at the vertex **420c**. The transitions from one member to its neighbor may be abrupt and sharply angled such as the vertex **420c**, or may be expanded and include at least one short span, such as a link vertex **420b**.

The armature **442** is configured as a generally U-shaped strap having first and second opposed legs **442a**, **442b**, respectively. One skilled in the art will appreciate the principles and advantages of the embodiments described herein may be useful with all types of receivers, such as those using an E-shaped armature. The armature **442** extends through the first air gap **428** of the drive coil **426** and the second air gap **436** of the magnet assembly **430**. A drive rod **444**, attached to the armature **442** adjacent to the free end of the first leg **442a**, is positioned within the housing **402**. The drive rod **444**, in turn, couples to the inner surface of the link member **420a**, for example by adhesive bonding, and hence to the remainder of the drive the linkage assembly **420**. The drive rod **444** may be made of a strip of material, such as metal or plastic, capable of vibrating in response to the acoustical signal. In alternate embodiment, the linkage assembly **420** and the drive rod **444** can be formed from the same stock and molded or press-fit to the linkage assembly **420** as a single unit. The magnet assembly **430** surrounds the

first leg **442a** of the armature **442** and provides a permanent magnetic field within the second air gap **436**.

At least one mounting member or spacer, two are illustrated as mounting members **450**, **452** are introduced to support and secure the linkage assembly **420**. The mounting members **450**, **452** may be adhesive bumps, may be formed portions of the housing **102**, and may be positioned between the linkage assembly **420** and the inner wall of the housing **402**. The thickness and materials of the mounting members **450**, **452** may vary depending on the requirements of the application. It will be understood that a variety of mounting members such as, for example, a glue fillet, may be utilized to support the linkage assembly **420**.

The outer surface of the mounting member **450** secures to the surface of the member **420a** by bonding or any suitable method of attachment, and the outer surface of the mounting member **450** is held in contact with the inner surface of the radiating face **422** by bonding or any suitable method of attachment. The outer surface of the mounting member **452** is held in contact with the inner surface of the bottom housing **106** by bonding or any suitable method of attachment. The outer surface of the mounting member **452** is held in contact with the surface of the member **420c** by bonding or any other suitable method of attachment.

In operation, excitation of the drive coil **426** magnetizes the armature **442**. Interaction of the first armature leg **442a** with the magnetic field causes the first armature leg **442a** to vibrate, which lead to the movement of the drive rod **444**. When the drive rod **444** moves in response to the motion of the first armature leg **442a** in the first direction, the link members **420a**, **420b**, and **420c** of the linkage assembly **420** move in the second direction in response to the drive rod **444**. The motion of the first armature leg **442a** is converted at the drive rod **444** and the member **420a** of the linkage assembly **420**, resulting in motion of the radiating face **422** of the housing **402** in the second direction. As an example, the movement by the first armature leg **442a** generates a movement of the drive rod **444** substantially aligned with the first direction, which in turn, generates a movement of member **420a** of the linkage assembly **420** substantially aligned with the second direction, resulting the movement of the radiating face **422** of the housing **402**. In other words, the movement of the first armature leg **442a** can cause the drive rod **444** to move in the direction indicated by the theta symbol.

The first and the second bellows-like members **414**, **416** of the housing **402** as shown in FIGS. **5** and **6** enclosed the drive coil **426**, the magnet assembly **430**, and the motor assembly **440** from the outside, but allow the radiating face **422** to move freely in horizontal motions (depicted as arrow B). Formed in this manner, the receiver assembly **400** has an increased amount of output acoustical signals without a conventional diaphragm and a sound port. In addition, the use of sound port is eliminated, thus allowing the receiver assembly **400** to be less susceptible to the accumulation of cerumen and moisture.

To further restrain large vibration in response to the vibration of the armature **442**, the second bellows-like member **416** as shown in FIG. **6**, is positioned inside the linkage assembly **420** to further restrain the motion of the mounting member **450** to a horizontal motion.

FIG. **8** illustrates another embodiment of a receiver assembly. The receiver assembly **500** includes a housing **502** having at least one sound outlet tube **503**. The housing **502** may be generally rectangular with a top portion **504**, a bottom portion **506**, and side wall portions **508**, **510**. In alternate embodiments, the housing **502** can be manufac-

ured in a variety of configurations, such as, a cylindrical shape, a D-shape, a trapezoid shape, a roughly square shape or any other desired geometry. In addition, the scale and size of the housing **502** may vary based on the intended application, operating conditions, required components, etc. Moreover, the housing **502** can be manufactured from a variety of materials, such as, for example stainless steel, alternating layers of conductive materials, alternating layers of non-conductive materials (e.g., metal particle-coated plastics), etc.

One or more apertures or acoustic ports **504a**, **504b** are introduced integral to the top portion **504** to broadcast an output acoustical signal that corresponds to an audio signal received at an electrical terminal. (not shown) positioned on an external surface of the housing **502**. In alternate embodiment, the acoustic ports **504a**, **504b** can be formed in the side walls **508**, **510**. The acoustic ports **504a**, **504b** may be formed in any suitable manner such as drilling, punching or molding. A sound outlet tube **503** is coupled to the top portion **504** by bonding with adhesive or any other suitable method. In an alternate embodiment, the sound outlet tube **503** can be formed integral to the side walls **508**, **510**. The sound outlet tube **503** can be manufactured from a variety of materials such as, for example, stainless steel, alternating layers of conductive materials, alternating layers of non-conductive materials (e.g. metal particle-coated plastics), etc. The sound outlet tube **503** can be formed in various shapes and may have a number of different sizes. The sound outlet tube **503** comprises a sound passage **512** to guide the output acoustical signal via acoustic ports **504a**, **504b** towards the user's eardrum. The sound passage **512** may be formed in any suitable manner such as drilling, punching or molding. An optional damping element or filter **514** may be positioned within the sound passage **512**. The damping element or filter **514** may provide an acoustical resistance to the receiver assembly **500**, may improve the frequency response, may create delay, and may prevent debris from entering the receiver assembly **500**. The receiver assembly **500** may further include a drive coil (not depicted) which may be located in side-by-side abutting alignment with a magnet assembly **530** within the housing **502** and an electrical terminal (not depicted) positioned on the external surface of the housing **502** for receiving an input audio frequency electrical signal.

The receiver assembly **500** further includes a magnet assembly **530** including a pair of drive magnets **534** fixedly attached to a magnetic yoke **532**. The magnet assembly **530** may generally be shaped to correspond to the shape and configuration of the housing **502** but may be formed to compliment the various shapes and sizes of other embodiments. The magnetic yoke **532** forms of a generally rectangular frame having a central tunnel or channel defining an enclosure into which the drive magnets **534** may mount and form an air gap. The magnetic yoke **532** is typically manufactured of a soft magnetic material having a high permeability and a high saturation induction such as, for example, nickel-iron alloy, iron-silicon alloy, cobalt-iron vanadium alloy, etc., having a thickness to carry the electromagnetic flux of the drive magnets **534** and the drive coil (not depicted). The drive magnets **534** are typically manufactured of a magnetic material such as a permanent magnetic material (e.g., Alnico, Ferrite) or a rare earth magnet material such as, for example Samarium-Cobalt (SmCo), Neodymium-Iron-Boron (NdFeB), having a thickness to provide sufficient electromagnetic flux density within the air gap.

The receiver assembly **500** may further include a motor assembly **540** including an armature **542**, a link or drive rod

544, and at least one linkage assembly 520. The linkage assembly 520 includes a plurality of link members 520a, 520b, 520c, 520d, 520e and vertices 520f, 520g. The linkage assembly 520 may be formed into a variety of shapes and configurations based on the intended application, operating conditions, required components, etc. The linkage assembly 520 is typically fabricated from a flat stock material such as a thin strip of metal or foil. Alternately, the linkage assembly 520 may be formed of plastic or some other material. Each of the link members 520a, 520b, 520c, 520d, 520e is illustrated as a substantially flat component connected together at the vertices 520f, 520g. The transitions from one link member to another link member may be abrupt and sharply angled such as shown at the exemplary vertices 520f, 520g, or may be curved or expanded and include at least one short span, such as the link member 520c. The armature 542 is configured as a generally U-shaped strap having first and second opposed legs 542a, 542b, respectively. In other embodiments, different types of armatures may be used such as E-shaped armatures. At least the leg 542a of the armature 542 extends through an air gap of the drive coil (not shown) and an air gap of the magnet assembly 530. One end of the drive rod 544 may be coupled to a free end of the first armature leg 542a. The other end of the drive rod 544 couples to an inner surface of the link member 520c by means of adhesive or any other suitable method. In an alternate embodiment, the member 520c may include an aperture to allow the drive rod 544 to extend therethrough and coupled to the member 520c by bonding or any other suitable method. Also, the linkage assembly 520 and the drive rod 544 can be formed from the same stock and molded or press-fit to the linkage assembly 520 to form one unit. The magnet assembly 530 provides a permanent magnetic field within the air gap of the of the drive magnet 534 through which the leg 542a if the armature 542 extends.

A first and second diaphragm assembly 550, 560 are introduced to increase the radiating area, each of whose reciprocating motion displaces air to produce acoustic output. The diaphragm assemblies 550, 560 include thin films 552, 562 and diaphragms 554, 564 attached to the thin films 552, 562. The diaphragm assemblies 550, 560 may have a generally rectangular shape that generally corresponds to that of the side portions 508, 510 but may take the form of various shapes and have a number of different of sizes in different embodiments. The diaphragm assemblies 550, 560 are secured to the outer surface of the magnet assembly 530 by bonding with adhesive or any other suitable attachment. In alternate embodiment, the diaphragm assemblies 550, 560 can be secured to the inner surface of the housing 502 by bonding with adhesive or any other suitable attachment. The diaphragms 554, 564 are shown to have at least one layer. However, the diaphragms 554, 564 may utilize multiple layers and coupled together by bonding with adhesive, compression, mechanical attachment at the edges, etc. The diaphragms 554, 564 can be manufactured from a variety of materials such as aluminum, stainless steel, beryllium copper, titanium, tungsten, platinum, copper, brass, or alloys thereof, non-metals such as modified ethylene vinyl acetate thermoplastic adhesive, thermo set adhesive, epoxy, polyimide (Kapton), plastic, plastic matrix, fiber reinforced plastic, etc., or multiples of these could be used. Formed in this manner, the diaphragm assemblies 550, 560 increase the radiating area to provide an output acoustical signal correspond to the input audio signal received at the electrical signal (not depicted) such that the acoustic pressures developed by the diaphragm assemblies 550, 560 are essentially in-phase with each other.

The diaphragm assemblies 550, 560 and the armature 542 are coupled to the linkage assembly 520. The first diaphragm assembly 550 is coupled to the linkage assembly 520 at or near the link member 520a by bonding or any other suitable method. The second diaphragm assembly 560 is coupled to the linkage assembly 520 at or near the link member 520e by bonding or any other suitable method.

In operation, excitation of the drive coil (not shown) in response to electronic signals at the electrical terminals (not shown) magnetizes the armature 542. Interaction of the first armature leg 542a with the magnetic field causes the first armature leg 542a to vibrate vertically, which leads to the movement of the drive rod 544. When the drive rod 544 moves in response to the vertical motion of the first armature leg 542a, the members of the linkage assembly 520 move in response to the drive rod 544. The vertical motion of the first armature leg 542a is converted into lateral motion at the members 520a, 520e of the linkage assembly 520, resulting in lateral motion of the diaphragms 554, 564 substantially perpendicular to the vertical motion of the first armature leg 542a. As an example, upward vertical movement by the first armature leg 542a in the direction F generates upward vertical movement of the drive rod 544 in the direction F, which in turn, generates upward vertical movement at member 520c of the linkage assembly 520 in the direction F. The upward vertical movement at member 520c of the linkage assembly 520 causes members 520a, 520e of the linkage assembly 520 to move inwardly toward each other generally perpendicular to the direction F, which in turn, causes the diaphragm 554 and the diaphragm 564 to move inwardly toward each other generally perpendicular to the direction F.

FIG. 9 illustrates yet another embodiment of a receiver assembly. The assembly 600 is similar in construction and function as the assembly 500 illustrated in FIG. 8, and similar elements are referred to using like reference numerals wherein, for example 600 and 650 correspond to 500 and 550, respectively. In this embodiment, a second linkage assembly 680 is introduced. The second linkage assembly 680 includes a plurality of link members 680a, 680b, 680c, 680d, 680e and vertices 680f, 680g. The second linkage assembly 680 may take the form of various shapes and configurations based on the intended application, operating conditions, required components, etc. The linkage assembly 680 is typically fabricated from a flat stock material such as a thin strip of metal or foil. Alternately, the linkage assembly 680 may be formed of plastic or some other material. Each of the link members 680a, 680b, 680c, 680d, 680e is illustrated as a substantially flat component connected together at the vertices 680f, 680g. The transitions from one link member to another link member may be abrupt and sharply angled such as 680f, 680g, or may be curved or even expanded and include at least one short span, such as vertex 680c. An outer surface of the vertex 680a may be coupled to an inner surface of the vertex 620a by bonding or any other suitable method. An outer surface of the vertex 680e may be coupled to an inner surface of the vertex 620e by bonding or any other suitable method. Alternatively, the first linkage assembly 620 and the second linkage assembly 680 can be formed from the same stock and molded or press-fit to the linkage assembly 620 to form one unit.

In operation, excitation of the drive coil (not shown) in response to the modified electronic signals at the electrical terminals (not shown) magnetizes the armature 642. Interaction of the first armature leg 642a with the magnetic field causes the first armature leg 642a to vibrate, which lead to the movement of the drive rod 644. When the drive rod 644 moves in response to a vertical motion F of the first armature

leg **642a**, the members of the linkage assemblies **620**, **680** move in response to the drive rod **644**. The vertical motion of the first armature leg **642a** is converted into lateral motion at the members **620a**, **620e** of the first linkage assembly **620** and members **680a**, **680e** of the second linkage assembly **680**, resulting in lateral motion of the diaphragm assemblies **650**, **660** substantially perpendicular to the vertical motion of the first armature leg **642a**. As an example, vertical movement by the first armature leg **642a** in the direction F generates upward vertical movement of the drive rod **644** in the direction F, which in turn, generates upward vertical movement at members **620c**, **680c** of the first and second linkage assemblies **620**, **680** in the direction F. The upward vertical movement at members **620c**, **680c** causes members **620a**, **680a** to move inwardly towards members **620e**, **680e**, and causes members **620e**, **680e** to move inwardly towards members **62a**, **680a**. This in turn causes diaphragms **654**, **664** to move inwardly toward each other. In another embodiment, an additional mass can be attached, for example, to the member **680c** of the second linkage assembly **680** to help decrease vibration of the receiver assembly **600**.

FIG. 10 illustrates still another embodiment of a receiver assembly. The assembly **700** is similar in construction and function as the assembly **500** illustrated in FIG. 8, and similar elements are referred to using like reference numerals wherein, for example **700** and **750** correspond to **500** and **550**, respectively. In this embodiment, a drive rod such as the drive rod **544** as shown in FIG. 8 is not required, but rather a linkage assembly **720** is coupled to an armature **742**. The linkage assembly **720** may include link members **720a**, **720b**, and **720c**, and a bottom surface of the link member **720c** may be coupled to a top surface of the armature leg **742a**. Vertical movement of the armature leg **742a** in the direction F generates upward vertical movement of the member **720c** in the direction F, resulting in movement of the diaphragms **754**, **764** generally perpendicular to the direction F and generally outwardly away from each other. In another embodiment, a bottom surface of the armature leg **742a** may be coupled to a top surface of the link member **720c**. Also, the linkage assembly **720** could be positioned such that movement of the armature leg **742a** in the direction F would cause movement of the diaphragms **754**, **764** generally inwardly toward each other.

FIG. 11 illustrates another embodiment of a receiver assembly. The assembly **800** is similar in construction and function as the assembly **500** illustrated in FIG. 8, and similar elements are referred to using like reference numerals wherein, for example **800** and **850** correspond to **500** and **550**, respectively. In this embodiment, acoustic ports **810a**, **810b** are introduced on a side wall **810** to broadcast an output acoustical signal that corresponds to an audio signal that is transmitted into the receiver assembly **800** via electrical terminal (not depicted). A sound outlet tube **803** corresponding to the acoustic ports **810a**, **810b** may be coupled to the side wall **810** of the housing **802**. In an alternate embodiment, the acoustic ports **810a**, **810b** can be formed on the side wall **808**, and the sound outlet tube **803** could be coupled to the side wall **808**.

As shown in FIG. 11, a linkage assembly **820** is shown generally quadrilateral, having a plurality of link members **820a**, **820b**, **820c**, **820d**, **820e**, **820f**, **820g**, **820h**, **820i**, **820j**, **820o** and vertices **820k**, **820l**, **820m**, **820n**. The linkage assembly **820** may take the form of various shapes (e.g., elliptical-like shape such as elongate circle, oval, ellipse, hexagon, octagon, circle, etc.). The link members **820a**, **820b**, **820c**, **820d**, **820e**, **820f**, **820g**, **820h**, **820i**, **820j**, **820o** are coupled together at vertices **820k**, **820l**, **820m**, **820n**. The

transitions from one member to its neighbor may be abrupt and sharply angled such as vertices **820k**, **820l**, **820m**, **820n**, or may be curved or expanded and include at least one short span, such as members **820a**, **820c**, **820e**, **820f**. A drive rod **844** may be coupled to the linkage assembly **820**. Also, the linkage assembly **820** and the drive rod **844** can be formed from the same stock and molded or press-fit to the linkage **820** to form one unit. The diaphragm assemblies **850**, **860** may be secured to an inner surface of a top portion **804** and an inner surface of a bottom portion **806** by bonding or any other suitable method. In an alternate embodiment, the diaphragm assemblies **850**, **860** can be secured to the outer surface of a magnet assembly **830** by bonding or any other suitable method of attachment. The diaphragm assemblies **850**, **860** and the armature **842** are coupled to the linkage assembly **820**. An inner surface of the first diaphragm assembly **850** is coupled to the linkage assembly **820** at or near the link member **820c** by bonding or any other suitable method of attachment. An inner surface of the second diaphragm assembly **860** is coupled to one end of the drive rod **844**. Another end of the drive rod **844**, in turn, is coupled to linkage assembly **820** at or near the link member **820f** by bonding or any other suitable method. A free end of an armature leg **842a** is coupled to the linkage assembly **820** at or near the link member **820f**. The motion of the vertices **820a**, **820e** of the linkage assembly **820** is partially constrained by link members **820i**, **820j**, **820o** of the linkage assembly **820**, thus restricting movement of the vertices **820a**, **820e** in directions parallel to the directions F and G. As an example, upward vertical movement by the first armature leg **842a** in the direction F generates a downward vertical movement of link member **820c**, resulting in downward vertical movement of the diaphragm **854** in the direction G. Upward vertical movement by the first armature leg **842a** in the direction F generates upward vertical movement of the drive rod **844**, resulting in upward vertical movement of the second diaphragm assembly **860** in the direction F. The opposing motions of the armature **842**, and the diaphragms **854**, **864** enable the vibration balancing of the receiver **800** over a wide frequency range. In an alternate embodiment, the moving mass of at least one of the diaphragm assemblies **850**, **860**, such as the first diaphragm assembly **850** can be increased to be substantially equal to the moving mass of the second diaphragm assembly **860**, the moving mass of the drive rod **844**, and the moving mass of armature leg **842a** to further reduce vibration of the receiver assembly **800**. Also, an additional mass could be attached, for example, to the link **820c**.

Referring now to FIG. 12, a receiver assembly **900** in accordance with a described embodiment of the invention. The assembly **900** is similar in construction and function as the assembly **800** illustrated in FIG. 11, and similar elements are referred to using like reference numerals wherein, for example **900** and **950** correspond to **800** and **850**, respectively. In this embodiment, a linkage assembly **920** is shown generally quadrilateral, having a plurality of link members **920a**, **920b**, **920c**, **920d**, **920e**, **920f**, **920g**, **920h**, **920i**, **920j** and vertices **920k**, **920l**, **920m**, **920n**. The linkage assembly **920** may take the form of various shapes (e.g., elliptical-like shape such as elongate circle, oval, ellipse, hexagon, octagon, circle, etc.). The members **920a**, **920b**, **920c**, **920d**, **920e**, **920f**, **920g**, **920h**, **920i**, **920j** and connected together at the vertices **920k**, **920l**, **920m**, **920n**. The transitions from one member to its neighbor may be abrupt and sharply angled such as vertices **920k**, **920l**, **920m**, **920n** compared to FIG. 8, or may be expanded and include at least one short span, such as members **920a**, **920c**, **920e**, **920f**. A drive rod

15

944 may be coupled to the linkage assembly 920. Also, the linkage assembly 920 and the drive rod 944 can be formed from the same stock and molded or press-fit to the linkage 920 to form one unit. The diaphragm assemblies 950, 960 may be coupled to an inner surface of a side portion 908 and an inner surface of a side portion 910 by bonding with adhesive. In alternate embodiment, the diaphragm assemblies 950, 960 can be secured to an outer surface of a magnet assembly 930 by bonding with adhesive. The diaphragm assemblies 950, 960 and the armature 942 are coupled to the linkage assembly 920. The inner surface of the first diaphragm assembly 950 is coupled to the linkage assembly 920 at or near the link member 920c by bonding or any other suitable method. One end of the drive rod 944 couples to a free end of an armature leg 942a. The other end of the drive rod 944 is coupled to an inner surface of the link member 920c by bonding or any other suitable method. An inner surface of the second diaphragm assembly 960 is coupled to the linkage assembly 920 at or near the link member 920g. The motion of the vertices 920a, 920e of the linkage assembly 920 is partially constrained by legs 920i, 920j of the linkage assembly 920, thus restricting movement of the vertices 920a, 920e in the direction generally parallel to F and in a direction opposite to F. As an example, upward vertical movement by the armature leg 942a in the direction F generates upward vertical movement of the drive rod 944, resulting in upward vertical movement of the diaphragm 954 via the upward vertical movement of the link member 920c in the direction F. Upward vertical movement by the first armature leg 942a generates downward vertical movement of link member 920f, resulting in downward vertical movement of the diaphragm 964. The opposing motions of the armature 942, and the diaphragms 954, 964 enables the vibration balancing of the receiver 900 over a wide frequency range. In an alternate embodiment, the moving mass of at least one of the diaphragm assemblies 950, 960, such as the second diaphragm assembly 960 can be increased to be substantially equal to the moving mass of the first diaphragm assembly 950, the moving mass of the drive rod 944, and the moving mass of armature leg 842a to further reduce vibration of the receiver assembly 900. Also, an additional mass could be attached, for example, to the link 920f.

In the embodiments described above with respect to FIGS. 8-12, two in-phase diaphragms are used. Thus, in these embodiments, it may be possible to increase the radiating area as compared to a receiver utilizing only one diaphragm. Also, it may be possible to generate a greater acoustical output as compared to a receiver utilizing only one diaphragm. Further, it may be possible to generate a similar acoustical output using less power as compared to a receiver utilizing only one diaphragm. In some implementations, a receiver assembly utilizing two in-phase diaphragms may not provide any of these advantages, but rather may provide different advantages.

Although various linkage assemblies have been described above and shown in the figures having link members of particular relative lengths, as well as ratios between lengths of link members, one of ordinary skill in the art will recognize that the relative lengths and ratios of lengths of link members may be varied in different implementations.

What is claimed is:

1. A receiver assembly comprising:

a housing having a fixed housing portion and a moveable housing portion;

a flexible membrane disposed between the fixed housing portion and the movable housing portion, wherein the

16

flexible membrane is adapted to allow relative motion between the fixed and moveable housing portions and to enclose the fixed and moveable housing portions to provide an enclosed housing;

a magnetic motor assembly positioned within the enclosed housing and including a displaceable drive rod; and

a link assembly disposed within the enclosed housing having a first end fixedly attached to an inner surface of the moveable housing and a second end coupled to the drive rod, wherein the link assembly translates the moveable housing portion relative to the fixed housing portion in response to the displacement of the drive rod; wherein the flexible membrane defines a bellows-like member adapted to flex between a compressed position and an extended position.

2. The receiver assembly of claim 1, wherein the flexible membrane is an accordion shaped connector.

3. The receiver assembly of claim 1, wherein the flexible membrane is a pliant sheet of material.

4. The receiver assembly of claim 1, wherein the flexible membrane is a formed integral with the housing.

5. The receiver assembly of claim 1, wherein the flexible membrane is a separate component disposed between and joins the fixed housing portion to the moveable housing portion.

6. The receiver assembly of claim 1, wherein the link assembly further comprises a first link including the first end and a second link including the second end, the first and second links flexibly connecting the drive rod to the inner surface of the moveable housing portion.

7. The receiver assembly of claim 1, wherein the first end of the link assembly fixed attached to a diaphragm member positioned adjacent to the inner surface of the moveable housing portion.

8. The receiver assembly of claim 1, wherein the link assembly is manufactured from a metallic rigid flat stock.

9. A receiver assembly including a magnetic motor assembly having a drive rod mounted to a free end of a translatable armature, the receiver assembly comprising:

an enclosed housing with the magnetic motor assembly being disposed within the enclosed housing, the enclosed housing including a flexible membrane arranged to divide the housing into a fixed housing portion and a moveable housing portion; and

a link assembly disposed within the enclosed housing including:

a first link member coupled to the drive rod; and

a second link member flexibly coupled to the first link member and fixedly attached to the moveable housing portion;

wherein the first and second link members cooperate to translate the moveable housing portion relative to the fixed housing portion in response to the movement of the armature and drive rod.

10. The receiver assembly of claim 9, wherein the flexible membrane is an accordion shaped connector.

11. The receiver assembly of claim 9 further comprising at least one raised formation positioned to restrict the translation of the armature and the coupled drive rod.

12. The receiver assembly of claim 9, wherein the link assembly further comprises a third link member fixedly attached to a fixed end of the translatable armature and a fourth link member flexibly coupled to the third link member and fixedly attached to the moveable housing portion,

17

wherein the third and fourth link members balance the first and second link members during the translation of the moveable housing portion.

13. The receiver assembly of claim 9, wherein a fifth link member flexibly coupled the fourth link member to the second link member, wherein the fifth link member fixedly attached to a diaphragm member positioned within the moveable housing portion.

14. The receiver assembly of claim 9, wherein the link assembly is manufactured from a metallic rigid flat stock.

15. A receiver assembly comprising:

a sealed housing having

a fixed housing portion adapted to enclose a magnetic motor assembly including a displaceable drive rod; and

a moveable housing portion flexibly attached to the fixed housing portion by a flexible membrane; and a link assembly having a first end fixedly attached to an inner surface of the moveable housing and a second end coupled to the drive rod, wherein the link assembly translates the moveable housing portion relative to the fixed housing portion in response to the displacement of the drive rod;

wherein the flexible membrane defines a bellows-like member adapted to flex between a compressed position and an extended position.

16. The receiver assembly of claim 15, wherein the link assembly is manufactured from a rigid flat stock.

17. The receiver assembly of claim 16, wherein the rigid flat stock is a metallic material.

18. The receiver assembly of claim 16, wherein the rigid flat stock is a plastic material.

18

19. The receiver assembly of claim 15, wherein the moveable housing portion includes a diaphragm member.

20. A receiver assembly comprising:

a sealed housing having

a fixed housing portion adapted to enclose a magnetic motor assembly including a displaceable drive rod; and

a moveable housing portion flexibly attached to the fixed housing portion by a flexible membrane; and a link assembly having a first end fixedly attached to an inner surface of the moveable housing and a second end coupled to the drive rod, wherein the link assembly translates the moveable housing portion relative to the fixed housing portion in response to the displacement of the drive rod;

the magnetic motor assembly includes an armature adapted to displace the drive rod in a substantially vertical manner.

21. The receiver assembly of claim 20, wherein the vertical displacement of the armature is constrained by at least one formation positioned adjacent to an armature free end.

22. The receiver assembly of claim 20, wherein the link assembly is manufactured from a rigid flat stock.

23. The receiver assembly of claim 22, wherein the rigid flat stock is a metallic material.

24. The receiver assembly of claim 22, wherein the rigid flat stock is a plastic material.

25. The receiver assembly of claim 20, wherein the moveable housing portion includes a diaphragm member.

* * * * *